

# RFB Recessed Floor Box INSTALLATION INSTRUCTIONS

Installation Instruction No.: 1 002 639 R2 – Updated December 2003

Walker® electrical systems conform to and should be properly grounded in compliance with requirements of the current National Electrical Code or codes administered by local authorities.

All electrical products may present a possible shock or fire hazard if improperly installed or used. Walker electrical products may bear the mark as UL Listed and/or Classified and should be installed in conformance with current local and/or the National Electrical Code.

**IMPORTANT: Please read all instructions before beginning.**

Products Covered: RFB4, RFB4-CI-1, RFB4-4DB, RFB4-SS

## RFB4 Recessed Floor Box:

### Before Concrete Pour:

**Step 1** Determine box location and conduit layout. Remove knockouts and attach proper conduit adapters (not supplied by Walker) to steel base.

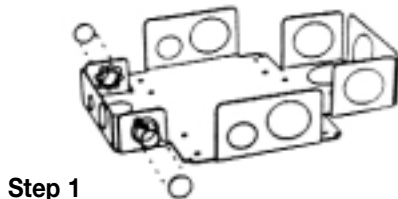

Step 1

**Step 2** Slip housing over base. Using the adjusting screws provided and adjust box so that top is 1/16" [1.6mm] below screed line.

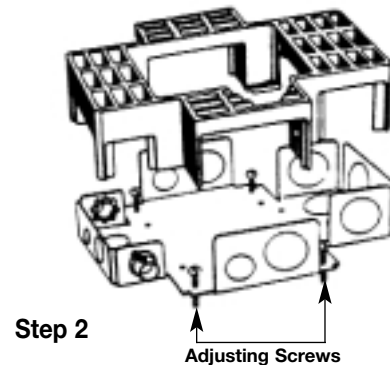

Step 2

**Step 3** Insert combination bracket inside of housing. Mount to base with four #10-24 x 5/8" [15.9mm] Phillips drive machine screws. If compartments (A) and (B) are used for different services, then one or both tunnel blocks must be pressed into the combination bracket to block the passage of wires between the two compartments. If pass-through is required between compartments (A) and (B), tunnel blocks are not needed. Pass-through is available only between compartments (A) and (B).

**Step 4** Secure box to subfloor using wire or nails through the slot adjacent to the adjusting screws. Once positioned, connect conduit to adapters.

**Step 5** Leave receptacle brackets in shrink wrapping and inside box until concrete is set and receptacles are ready to be installed.

**Step 6** Insert unused tunnel blocks into fingers of combination bracket. Place brackets in box and insert mudcap on top of blocks.

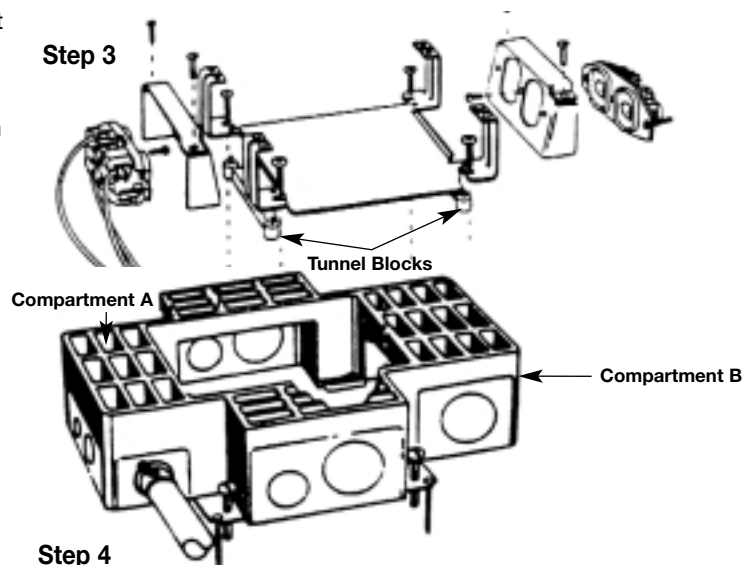

**WARNING:** Pour concrete to 1/16" [1.6mm] above box housing. Pours of 1/4" [6.4mm] or more over box housing will make it difficult to breakout the mudcap and cause excessive spalling.

---

## After Concrete Pour:

**Step 7** Locate box and chip away concrete located in mudcap. Remove mudcap and device plates. Remove tunnelblocks from the combination bracket fingers. Clean out any debris. If concrete does not break cleanly around preset, the activation might not be properly supported. If edges of FloorPort™ Activations are not supported by concrete on all sides, repair of excessive concrete spalling is required.

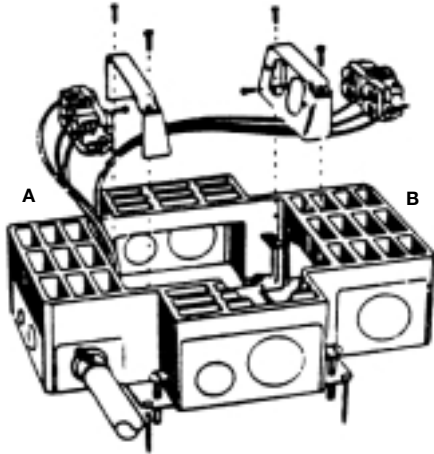

**Step 8** Wire devices (not supplied by Walker) in accordance with the National Electrical Code or any local code that applies. Make sure that any ground leads are connected to ground screws. Attach the receptacle to the receptacle mounting bracket using #6-32 screw provided. Attach the receptacles to the receptacle mounting brackets with two additional screws and nuts (not provided). Attach the receptacle mounting bracket to the combination bracket using two #10-24 mounting screws provided.

**Step 9** Complete procedure by installing a Walker FloorPort Activation (sold separately) using the installation instructions provided with the unit.

**This box and activation are UL Listed for use with tile, terrazzo, and carpet floors.**

---

Use insulator provided with the following catalog numbers:  
**RFB-GFI, CIHT-GFI, RFB-GFI-SS, RFB-GFI-4DB.**

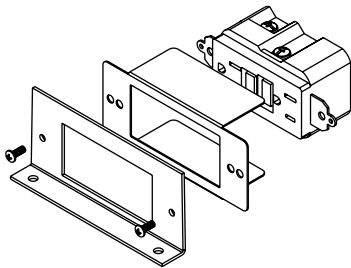

## RFB4-4DB Recessed Floor Box:

### Before Concrete Pour:

- Step 1** Remove knockouts and attach conduit to base using proper conduit adapters (not supplied by Walker).
- Step 2** Slip housing over base. Using the adjusting screws provided adjust box so that top is 1/16" [1.6mm] below screed line.
- Step 3** Once positioned, connect conduit to adapters and anchor box to the subfloor by wire or nails through the slot adjacent to the adjusting screws.
- Step 4** If all four compartments are not being used for single service, tunnel blocks may be installed to provide service isolation when feedback through wiring is not required (see Tunnel Block Arrangements Illustration).
- Step 5** Insert combination bracket inside of housing and mount to base with four #10-24 x 5/8" [15.9mm] machine screws.
- Step 6** Leave receptacle brackets in shrink wrapping until concrete is set and receptacles are ready to be installed.
- Step 7** Insert unused tunnel blocks inside of box and insert mudcap.

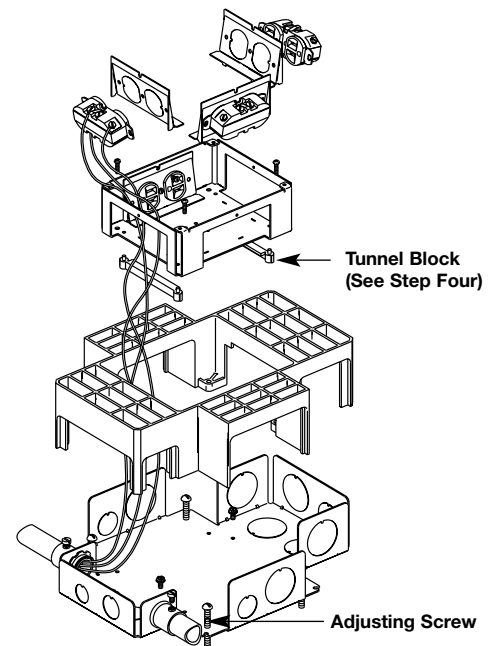

**WARNING:** Pour concrete to 1/16" [1.6mm] above box housing. Pours of 1/4" [6.4mm] or more over box housing will make it difficult to breakout the mudcap and cause excessive spalling.

**WARNING:** Compartments for power applications must be configured to allow either direct access or via tunneling to one of the two grounding screws in either compartment.

### After Concrete Pour:

- Step 1** Locate box and chip away concrete located in mudcap. Remove mudcap and unused tunnel blocks. Clean out any debris.

**WARNING:** If concrete does not break cleanly around preset, the activation might not be properly supported. If edges of FloorPort Activations are not supported by concrete on all sides, repair of excessive concrete spalling is required.

- Step 2** Attach receptacles (not supplied by Walker) to the receptacle brackets, using #6-32 screw provided. Attach the receptacles to the receptacle mounting brackets with two additional screws and nuts (not provided). Wire devices (not supplied by Walker) in accordance with the National Electrical Code or any local code that applies. Make sure that any ground leads are connected to ground screws before securing receptacle brackets using #6-32 x 3/8" [9.5mm] R.H.M.S.

- Step 3** Complete procedure by installing a Walker FloorPort Activation using the instructions provided with the unit.

**This box and activation are UL Listed for use with tile, terrazzo, and carpet floors.**

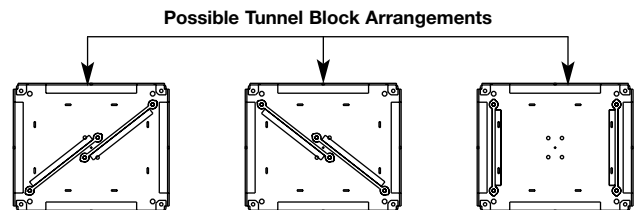

## RFB4-CI-1 Recessed Floor Box:

### Before Concrete Pour:

- Step 1** Remove conduit opening hole plugs and attach conduit to housing in accordance with local codes.
- Step 2** Align cover plate over top of housing and secure in place with four #8-32 x 3/8" [9.5mm] machine screws.
- Step 3** Using the adjusting screws supplied, adjust box so that the flat surface of the cover plate is 3/4" [19.1mm] below the screed line.

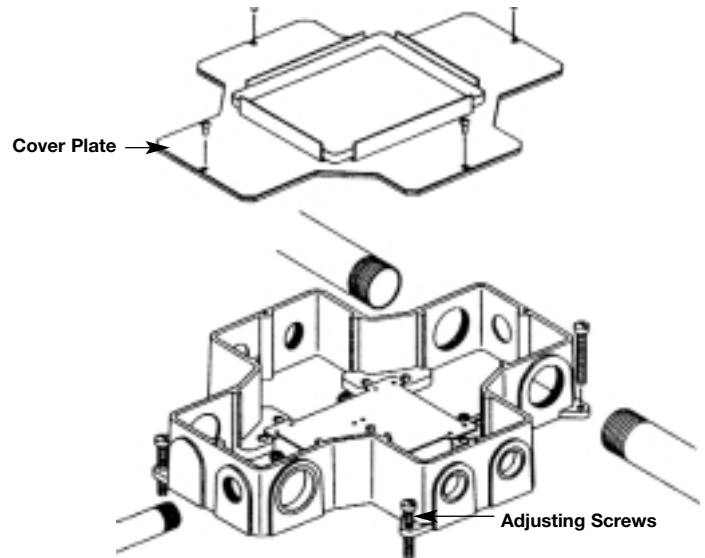

### After Concrete Pour:

- Step 4** Locate box and chip away concrete located in mudcap. Remove mudcap and device plates. Clean out any debris.

- Step 5** Remove wiring compartment cover by first removing the #8-32 x 3/8" [9.5mm] machine screw and then lifting the cover out of box (a small tip screwdriver used as a lever will help in removing cover).

**WARNING:** If concrete does not break cleanly around preset, the activation might not be properly supported. If edges of FloorPort Activations are not supported by concrete on all sides, repair of excessive concrete spalling is required.

- Step 6** Wire devices (not supplied by Walker) in accordance to the National Electrical Code or any local code that applies. Make sure that any required ground leads are connected to the ground screws before securing receptacle brackets in place. Connect receptacles to the receptacle brackets using the #6-32 screw provided. Attach the receptacle to the receptacle mounting bracket with two additional screws and nuts (not provided).

- Step 7** Secure receptacle brackets to box by first loosening the mounting screws a few turns. Next, position top of bracket in place and pivot the forked ends under mounting screws. Tighten mounting screws.

- Step 8** Make sure that wires in tunnel area are not kinked or pinched. Attach tunnel blocks to wiring compartment cover to isolate one compartment from the other as required (see Tunnel Block Arrangement Illustration). Secure wiring compartment cover to box with #8-32 x 3/8" [9.5mm] screws.

- Step 9** Complete installation by installing a Walker FloorPort Activation using the instructions provided with the unit.

**This box and activation are UL Listed for use with tile, terrazzo, and carpet floors.**

### Possible Tunnel Block Arrangements

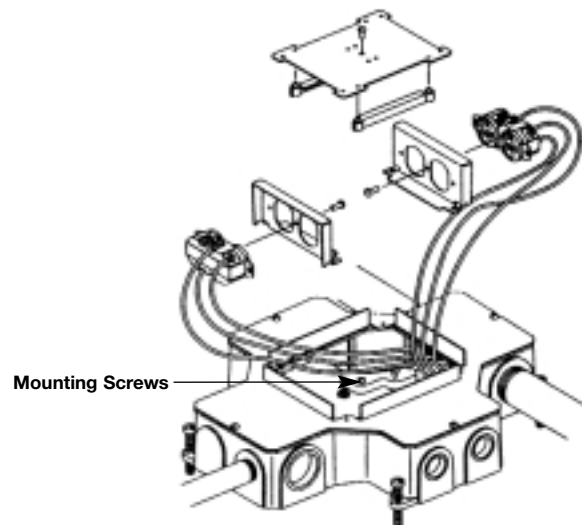
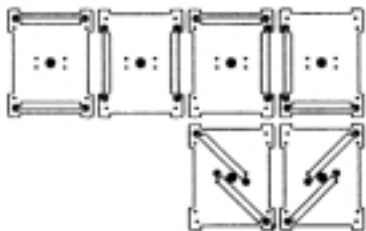

## RFB4-SS Shallow-Steel Recessed Floor Box: Before Concrete Pour:

**Step 1** Determine box location and conduit layout. Remove knockouts and attach proper conduit adapters (not supplied by Walker) to steel base.

**Figure 1**

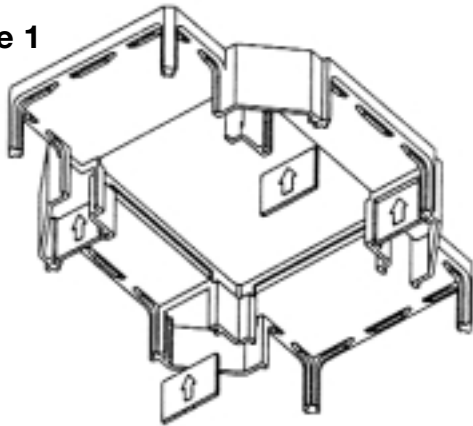

**Step 2** Select internal compartments of box which are to be used for power. Service isolation may be acquired by plastic housing. Power compartments must be arranged adjacent to one another to utilize the “pass-around” tunneling system (see Figure 1).

**NOTE:** Make sure proper compartments are isolated before concrete placement as barriers must be broken out rendering the barrier useless and possibly breaking the plastic housing.

**Step 3** Slip housing over base. Insert retaining bracket inside housing and secure to base using four #10-24 x 3/16" [4.8mm] screws provided (see Figure 2).

**Step 4** Adjust box so that top of housing is 1/16" [1.6mm] below screed line using the leveling screws provided. Secure box to subfloor using wire or nails through the slots adjacent to the adjusting screws. Once positioned, connect conduit to fittings.

**Step 5** Leave receptacle brackets in plastic bags until concrete is set and receptacles are ready to be installed. Place brackets in box and insert mudcap.

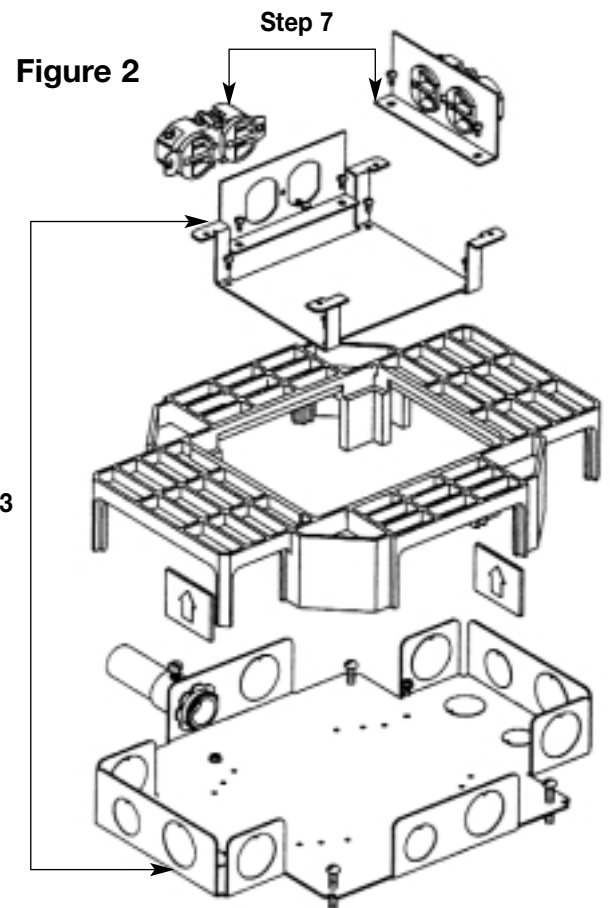

## After Concrete Pour:

**Step 6** Locate box and chip away concrete located in mudcap. Remove mudcap and device plates from the box. Clean out any debris.

**WARNING:** If concrete does not break clearly around preset, the activation might not be properly supported. If edges of FloorPort Activations are not supported by concrete on all sides, repair of excessive concrete spalling is required.

**Step 7** Wire devices (not supplied by Walker) in accordance with the National Electrical Code or any local code that applies. Make sure that any ground leads are connected to ground screws. Connect receptacles to receptacle brackets using #6-32 x 3/8" [9.5mm] screws (see Figure 2). Attach the receptacle to the receptacle mounting bracket with two additional screws and nuts (not provided). Secure receptacle brackets to base using remaining #10-24 x 3/16" [4.8mm] screws.

**Step 8** Complete procedure by installing a Walker FloorPort Activation (sold separately) using the installation instructions provided with the unit.

**This box and activation are UL Listed for use with tile, terrazzo, and carpet floors.**



**The Wiremold Company**

*U.S. and International:*

60 Woodlawn Street • West Hartford, CT 06110

1-800-621-0049 • FAX 860-232-2062 • Outside U.S.: 860-233-6251

*Canada:*

850 Gartshore Street • Fergus, Ontario N1M 2W8

1-800-741-7957 • FAX 519-843-5980

